Content

Section 1

Overview 1-1

- 1.1 SK-2224 Description 1-1
- 1.2 How to Contact Silent Knight 1-1

Section 2

Agency Requirements 2-1

- 2.1 FCC Warning 2-1
- 2.2 Underwriters Laboratories (UL) 2-1
 - 2.2.1 Requirements for All Installations 2-1
 - 2.2.2 Requirements for Local Protected Fire Alarm Systems 2-1

Section 3

Before You Begin Installing 3-1

- 3.1 What's in the Box? 3-1
- 3.2 Optional Accessories 3-2
- 3.3 SK-2224 Board Layout 3-3
- 3.4 Electrical Specifications 3-4
- 3.5 Environmental Specifications 3-4
- 3.6 Mounting the SK-2224 3-5
- 3.7 Assembly 3-6
- 3.8 Wiring Specifications 3-7
- 3.9 Calculating Current Draw and Standby Battery 3-8
 - 3.9.1 Worksheet Requirements 3-8
 - Filling in the Current Draw Worksheet, Table 3-6 (Section 3.9.3) 3-8
 - 3.9.2 Maximum Battery Standby Load 3-8
 - 3.9.3 Current Draw Worksheet 3-9

Section 4

Hardware Installation 4-1

- 4.1 AC Power 4-1
- 4.2 Battery Connection 4-2
- 4.3 Initiation Circuit Installation 4-3
 - 4.3.1 Contact Wiring 4-3
 - 4.3.2 Two-Wire Smoke Detector Wiring 4-3
 - 4.3.3 Four-Wire Smoke Detector 4-4
 - 4.3.4 Notification Circuit Installation 4-5
- 4.4 Alarm and Trouble Relays 4-5
- 4.5 Auxiliary Power Circuit 4-5
- 4.6 Door Release Wiring 4-6

| | | |
|-------|--|------|
| 4.7 | Optional Accessories Installation | 4-7 |
| 4.7.1 | Installing the Serial Driver Board (Model SK-2884) | 4-7 |
| | Wiring the SK-2884 to an Expansion Device | 4-8 |
| 4.7.2 | SK-2865 LED Annunciator Installation | 4-8 |
| | SK-2865 Electrical Specification | 4-8 |
| | Wiring the SK-2865 to the SK-2884 | 4-8 |
| | Setting the SK-2865's address | 4-10 |
| | Mounting the SK-2865 | 4-10 |

Section 5

System Configuration 5-1

Section 6

System Operation 6-1

| | | |
|-----|---------------------------------|-----|
| 6.1 | Meaning of LEDs | 6-1 |
| 6.2 | Operation Keys (Switches) | 6-3 |

Appendix A

Compatible Devices A-1

| | | |
|-------|------------------------------------|-----|
| A.1 | Smoke Detectors | A-1 |
| A.1.1 | Enhanced Mode | A-1 |
| A.1.2 | Two-Wire Smoke Detectors | A-2 |
| A.1.3 | Four-Wire Smoke Detectors | A-4 |
| A.2 | Notification Appliances | A-5 |
| | General Terms and Conditions | 1 |
| | Repair and RA Procedure | 1 |
| | Advanced Replacement Policy | 1 |
| | Limited Warranty | 2 |

Section 1

Overview

1.1 SK-2224 Description

The Model SK-2224 is a two zone, 24-volt fire control panel having the following features:

- Two Class B zones
- Two notification circuits rated at 1.25 amp each
- 2.5 amp power supply
- Dedicated alarm and trouble relays
- Auxiliary power output (.5 amp max.) for powering special applications, such as door holders.
- Enhanced Verification Mode, a built-in feature that distinguishes two-wire smoke detectors from pull stations.
- Housed in a 12-13/16"W x 15-1/8"H x 3-3/8"D metal cabinet
- Cabinet supports two 7.0 AH backup batteries

1.2 How to Contact Silent Knight

If you have a question or encounter a problem not covered in this manual, contact Silent Knight Technical Support at 800-328-0103 (or 612-493-6455). To order parts, contact Silent Knight Sales at 800-446-6444 (or 612-493-6435).

Section 2

Agency Requirements

2.1 FCC Warning

This device has been verified to comply with FCC Rules Part 15. Operation is subject to the two following conditions: (1) This device may not cause radio interference, and (2) This device must accept any interference received, including interference that may cause undesired operation.

2.2 Underwriters Laboratories (UL)

The SK-2224 is UL listed as a control unit for use in NFPA 72 systems. If the SK-2224 and its accessories are to be used as part of a UL installation, carefully read the UL requirements in this section. For more information on NFPA 72 standards, refer to the *NFPA National Fire Alarm Code, 1996 Edition*.

2.2.1 Requirements for All Installations

General requirements are described in this section. When installing an individual device, refer to the specific section of the manual for additional requirements.

1. All field wiring must be installed in accordance with NFPA 70 National Electric Code.
2. Use UL listed smoke detectors and notification appliances compatible with the SK-2224 from those specified in the Appendix to this manual.
3. If you are using the smoke verification feature:
 - Do not use smoke detectors with built-in alarm verification.
 - Select "Enhanced Mode" if the installation includes pull stations or water flow switches.
4. A full system checkout must be performed any time the panel is programmed.
5. UL installations require use of Model 7628 EOL resistor assembly.

2.2.2 Requirements for Local Protected Fire Alarm Systems

At least one UL listed supervised notification appliance must be used.

Section 3

Before You Begin Installing

3.1 What's in the Box?

The Model SK-2224 ships with the following hardware:

Table 3-1: Contents of Shipping Box

| Main Part | Containing | | Model Number |
|-------------------------|------------------|----------------------------------|--------------|
| | Part | Quantity/Item | |
| 1 Cabinet | | | 122509 |
| | Panel Bag | 1 Control Board | 202224 |
| | | 1 Installation/ Operation Manual | 151051 |
| | Hardware Bag | 2 #8 Screws | 119152 |
| | | 2 #8 Nuts | 119538 |
| | | 3 Self-tapping Screws | 119296 |
| | | 1 Earth Ground Wire | 140668 |
| | | 1 Battery Wire Harness | 130420 |
| 1 battery Jumper | | 140694 | |
| 1 Transformer | 120 Vrms @ 60Hz | | 115061 |
| | or a | | |
| | 230 Vrms at 50Hz | | 115031 |
| 1 Viewing Bezel | | | 122508 |
| 4 End-of-line Resistors | | | 111682 |

Note: See Section 3.7 for assembly instructions.

3.2 Optional Accessories

Table 3-2 is a list of optional accessories that can be used with the Model SK-2224 Fire Control Panel.

Table 3-2: Option Accessories for the SK-2224

| Model Number | Name | Description |
|--------------|---------------------------------------|--|
| SK-2884 | Serial Driver Board | Used to interface all SK-2224 expansion device to the SK-2224 panel. Supports 1 Dialer (Model SK-2104) and any combination of 4 LED Annunciators (Model SK-2865) or I/O Modules (Model SK-2880). |
| *SK-2880 | Input/Output (I/O) Module | Used to drive customized annunciators and interface devices. |
| *SK-2865 | LED Annunciator | Remote LED annunciator with Silence and Reset keyswitch inputs. |
| *SK-2104 | Digital Dialer | Used to communicate alarms, trouble and supervisories to central station. Offers 5 different reporting formats 3/1, 4/2, BFSK, SIA, and Contact ID. |
| 7628 | UL listed End-of-line (EOL) Resistor. | EOL resistor required for UL installations. |

* Requires a SK-2884 to operate with the SK-2224 control panel.

3.3 SK-2224 Board Layout

Figure 3-1 shows the SK-2224 circuit board including location of terminals, connectors, dip switches, and LEDs.

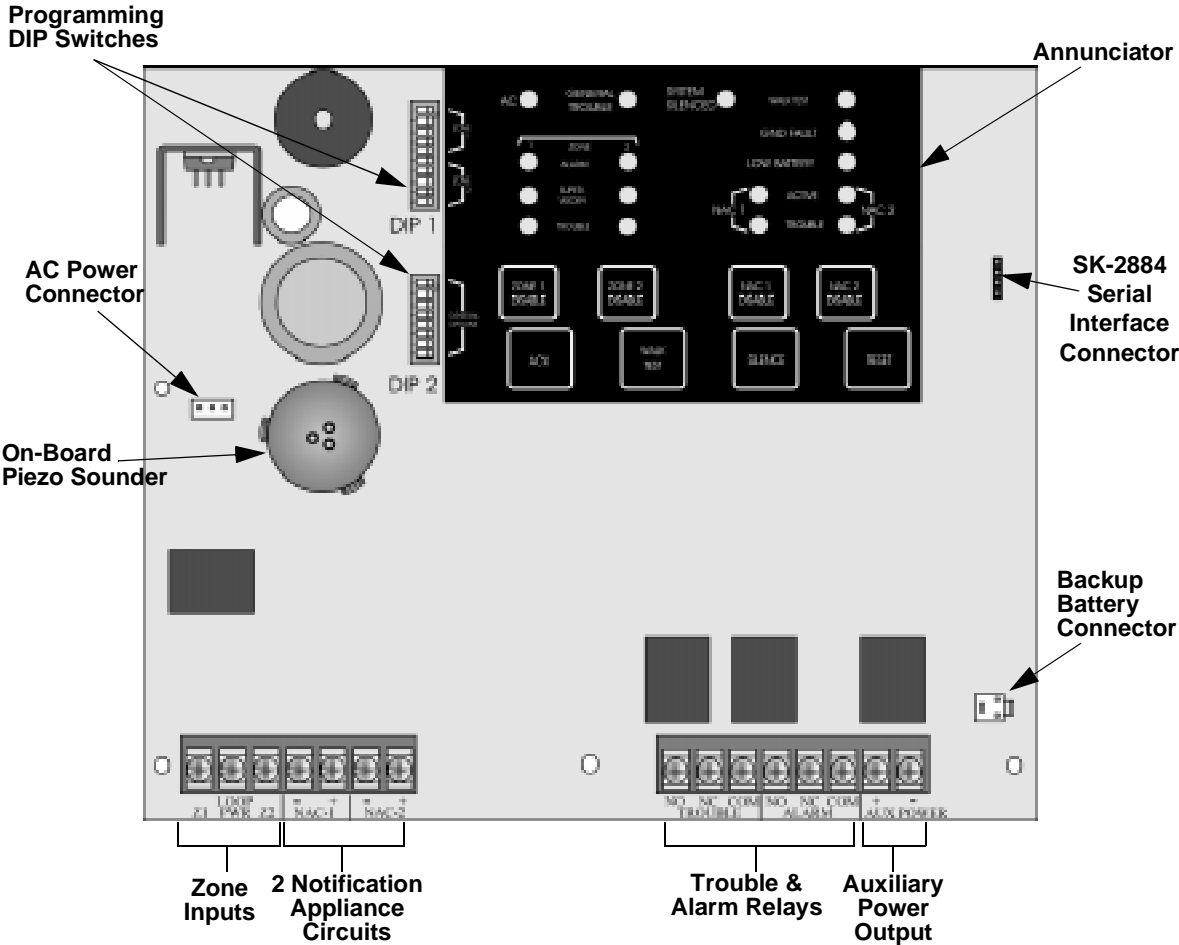

Figure 3-1 Model SK-2224 Layout

3.4 Electrical Specifications

Table 3-3: Electrical Specifications

| Circuit | Rating |
|----------------------------------|--|
| Primary AC | *120 Vrms at 60 Hz, or 230 Vrms at 50 Hz |
| Total External DC Load | 2.5A @ 24 VDC |
| +24V Auxiliary Power | 19.8 V to 28.0 V, 0.5 A max. |
| Trouble & Alarm Relays | 2.5 A @ 30 VDC resistive |
| Notification Appliance Power | 19.8 V to 28.0 V, 1.25 A max. each |
| Smoke Detector Power | 19.8 V to 28.0 V, 1.0 A max. |
| Battery Charging Voltage | 27.0 - 27.6 V |
| Maximum Battery Charging Current | 750 mA |
| Minimum Low Battery Detect | 20.4 V |
| Minimum Low AC Detect | 100 Vrms at 60 Hz, full load |

Note: * When ordering, specify your voltage requirements.

3.5 Environmental Specifications

Table 3-4: Environmental Specifications

| | |
|------------------------|----------------------------|
| Storage Temperature: | -4° - 167° F (-20 - 75° C) |
| Operating Temperature: | 32° - 120° F (0° - 49° C) |
| Humidity: | 10 - 85% non-condensing |

It is important to protect the SK-2224 control panel from water. To prevent water damage, the following conditions should be AVOIDED when mounting the units:

- Do not mount directly on exterior walls, especially masonry walls (condensation)
- Do not mount directly on exterior walls below grade (condensation)
- Protect from plumbing leaks
- Protect from splash caused by sprinkler system inspection ports
- Do not mount in areas with humidity-generating equipment (such as dryers, production machinery)

3.6 Mounting the SK-2224

Read the environmental specifications in Section 3.5 before mounting the cabinet.

The panel should be accessible to main drop wiring runs. It should be mounted as close to the center of the building as possible and located within a secured area, but should be accessible for testing and service. End-users responsible for maintaining the panel should be able to hear alarms and troubles. When selecting a location, keep in mind that the panel itself is the main source of alarm and trouble annunciation.

Mount the cabinet so it is firmly secured to the wall surface. When mounting the cabinet on concrete, especially when moisture is expected, attach a piece of 3/4-inch plywood to the concrete surface and then attach the cabinet to the plywood. Also mount any other modules to the plywood.

Follow these steps to mount the control panel cabinet:

1. Place the cabinet on the mounting surface, level the cabinet and mark the top two mounting holes.
2. Screw the top two mount screws about 3/4 of the way into the mounting surface.
3. Hang the control panel cabinet on the top mounting screws through the top mounting screw keyholes.

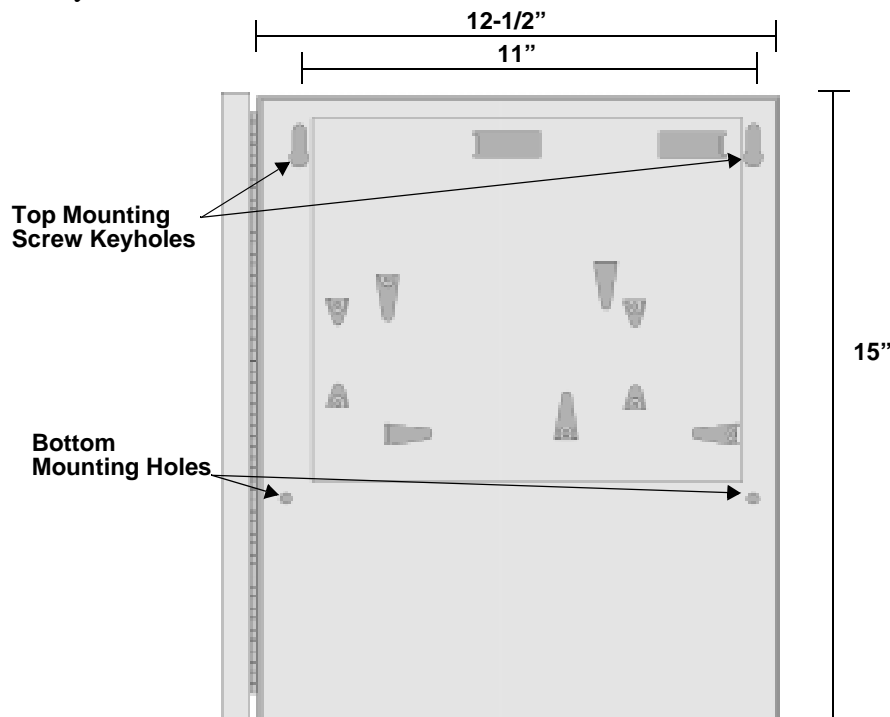

Figure 3-2 Cabinet Mounting Holes

4. Insert the bottom two mounting screws into the cabinet's bottom mounting holes.
5. Tighten all four mounting screws until the cabinet is properly secured.
6. Insert all cabinet components. See Section 3.7.

3.7 Assembly

The components listed in Table 3-1 are all packed within the cabinet and require some assembly. Follow these steps to assemble the components inside the cabinet:

1. Remove keys from small manila envelope taped to the top of the cabinet.
2. Unlock the cabinet door.
3. Remove the packing material and the SK-2224 components.
4. Snap the bezel into the opening in the front of the cabinet. See Figure 3-3.

Note: The bezel will fit in only one way.

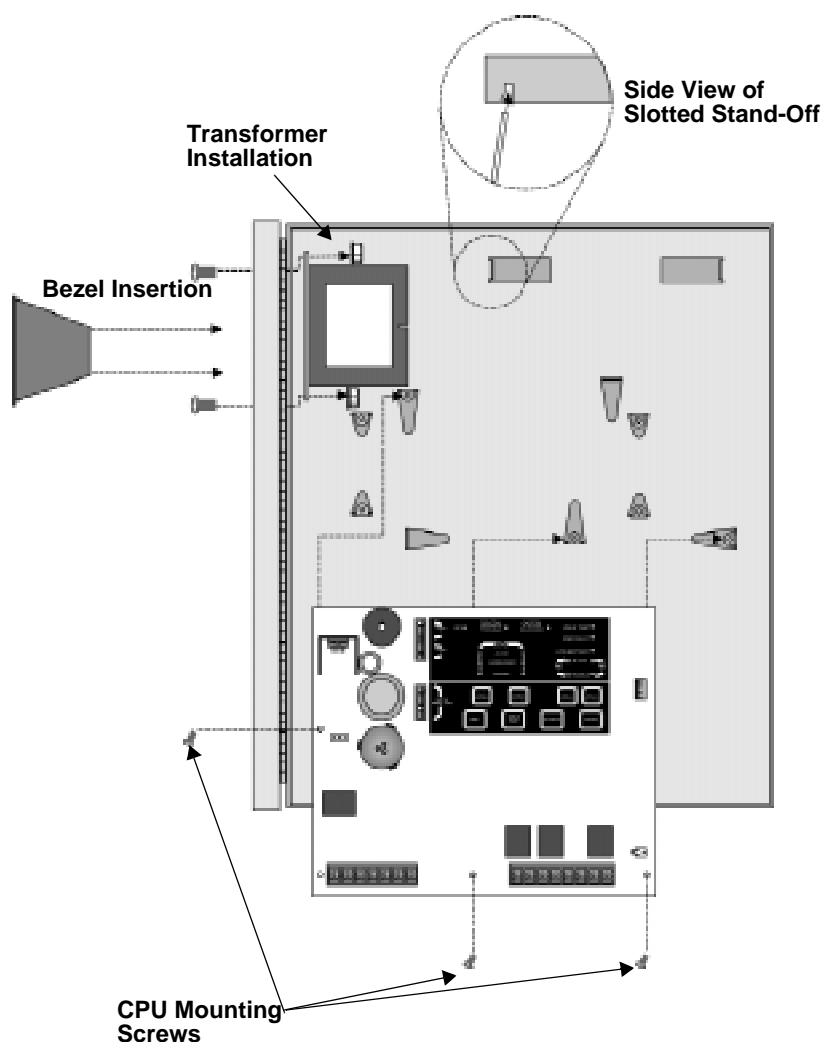

Figure 3-3 The SK-2224 Assembly Diagram

5. With the two #8 screws and the two #8 nuts (with built in washers), mount the transformer in the holes in the upper left hand corner of the cabinet. See Figure 3-3.
6. With the three self-trapping screws mount the control board on the cabinet stand-offs.

Note: See Section 4 for transformer connections and battery connections.

3.8 Wiring Specifications

Induced noise (transfer of electrical energy from one wire to another) can cause false alarms or interfere with control panel operation in other ways.

To avoid induced noise, follow these guidelines:

- Isolate input wiring from high current output and power wiring. Do not pull one multiconductor cable for the entire panel. Instead, separate the wiring as follows:

High current input/output: AC power, speaker, and notification device wiring

Low current input/output: Annunciator and zone loop wiring

Audio input/output: Telephone wiring

- Do not pull wires from different groups through the same conduit. If you must run them together, do so for as short a distance as possible or use shielded cable. Connect the shield to circuit ground at the panel. You must route high and low voltages separately.
- Route the wiring within the cabinet around the perimeter of the cabinet. It should not cross the printed circuit board where it could induce noise into the sensitive microelectronics or pick up unwanted RF noise from the high speed circuits. See Figure 3-4 for an example.
- High frequency noise, such as that produced by the inductive reactance of a speaker or bell, can also be reduced by running the wire through ferrite shield beads or by wrapping it around a ferrite toroid.

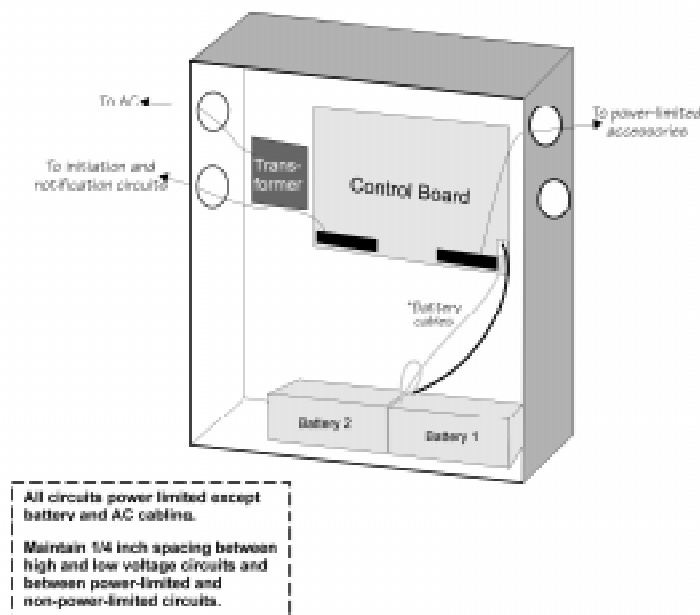

Figure 3-4 Wire Routing Example

3.9 Calculating Current Draw and Standby Battery

This section is for helping you determine the current draw and standby battery needs for your installation.

3.9.1 Worksheet Requirements

The following steps must be taken when determining SK-2224 current draw and standby battery requirements.

Filling in the Current Draw Worksheet, Table 3-6 (Section 3.9.3)

1. For the SK-2224, the worst case current draw is listed for the panel and is recorded in the table at Line A.
2. Add up the current draw for all smoke detectors and record in the table at Line B.
3. Add up all notification appliance loads and record in the table at Line C.
4. Any additional devices should be recorded at Line D.
5. Make sure that the alarm current without the panel (Lines B-D) does not exceed 2.5 A. The total alarm current (including the panel, Lines A-D) should not exceed 2.75 A.
6. Complete the remaining instructions in Table 3-6 for determining battery size requirements.

3.9.2 Maximum Battery Standby Load

Table 3-5 shows the maximum battery standby load for the SK-2224 based on 24 hours of standby. The standby load calculations of line D in the Current Draw Calculation Worksheet (Table 3-6) must be less than the number shown in Table 3-5 for the battery size used and standby hours required.

Table 3-5: Maximum Battery Standby Load

| Rechargeable Battery Size | Max. Load for 24 hrs. Standby, 5 mins. Alarm |
|---------------------------|--|
| 7 AH | 270 mA |

3.9.3 Current Draw Worksheet

Use this worksheet to determine current requirements during alarm/battery standby operation. (Copy this page if additional space is required.)

Table 3-6: Current Draw Calculations

| Device | Number of Devices | Current per Device | Standby Current | Alarm Current | |
|--|--|--|-----------------|---------------|-------------------------------|
| For each device, use this formula: | | This Column X | This column | = | Current per number of devices |
| A | SK-2224 Panel | Standby: | 100 mA | 100 mA | |
| | | Alarm: | 250 mA | | 250 mA |
| | | Current Subtotals: | | 100 mA | 250 mA |
| Smoke Detectors | | Refer to device manual for current ratings. See Appendix to this manual for max. # per loop. | | | |
| B | | Standby: | mA | mA | |
| | | Alarm: | mA | | mA |
| | | Standby: | mA | mA | |
| | | Alarm: | mA | | mA |
| | | Standby: | mA | mA | |
| | | Alarm: | mA | | mA |
| Current Subtotals: | | mA | mA | | |
| Notification Devices | | Refer to device manual for number of devices and current ratings. | | | |
| C | | Standby: | mA | mA | |
| | | Alarm: | mA | | mA |
| | | Standby: | mA | mA | |
| | | Alarm: | mA | | mA |
| | | Current Subtotals: | | mA | mA |
| | | Accessory Devices | | | |
| D | SK-2884 | Standby: | 10 mA | mA | |
| | | Alarm: | 10 mA | | mA |
| | SK-2865 | Standby: | 35 mA | mA | |
| | | Alarm: | 75 mA | | mA |
| Current Subtotals: | | mA | mA | | |
| *Additional Devices | | | | | |
| E | | Standby: | mA | mA | |
| | | Alarm: | mA | | mA |
| | | Standby: | mA | mA | |
| | | Alarm: | mA | | mA |
| Current Subtotals: | | mA | mA | | |
| Total current rating of all devices in system (add A through E): | | | mA | mA | |
| F | Total current ratings converted to amperes (x .001): | | | A | A |

**Note: If you are using door holders, you do not need to consider door holder current for alarm/battery standby, because power is removed during that time. However, during normal operation, door holders draw current and must be included in the total current that can be drawn from the panel.*

Section 4

Hardware Installation

4.1 AC Power

At installation, connect the transformer AC inputs to the AC power source as shown in Figure 4-1. It may be necessary for a professional electrician to make this connection.

The AC inputs are rated as 120 VAC, 60 Hz or 230 VAC, 50 Hz. See Table 3-1 for more information.

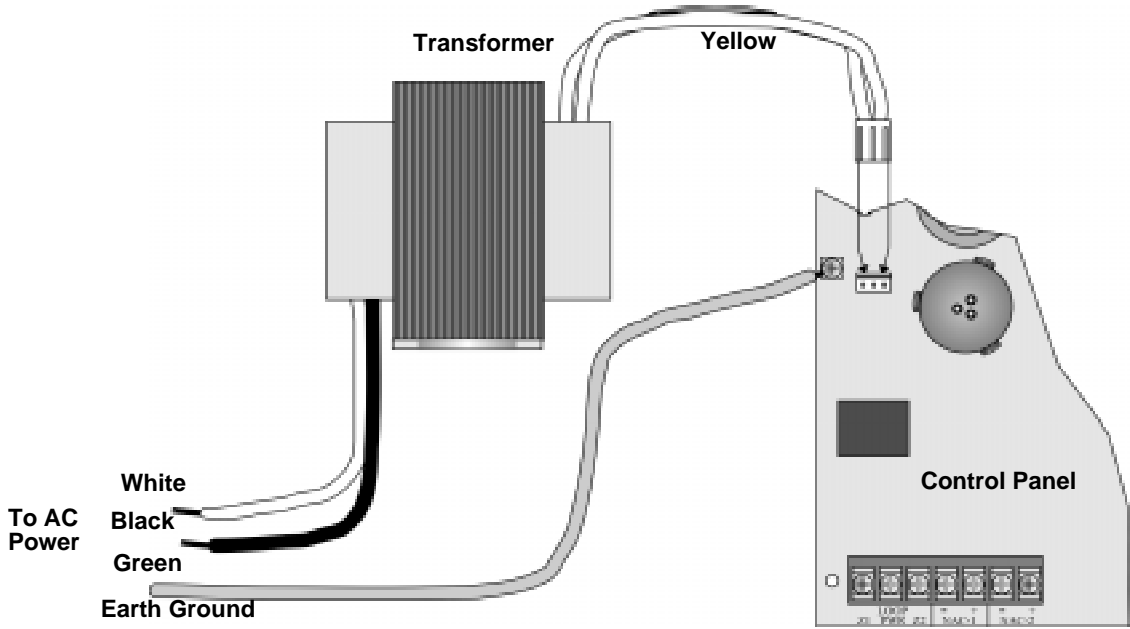

Figure 4-1 AC Power Connection

4.2 Battery Connection

The SK-2224 battery charge capacity is 7.0 AH. Use two 12V batteries of the same AH rating. Determine the correct AH rating as per your current load calculation (see Table 3-6).

Wire batteries in series to produce a 24-volt equivalent. Do not parallel batteries to increase the AH rating.

Note: The SK-2224 cabinet supports two 7.0 AH batteries.

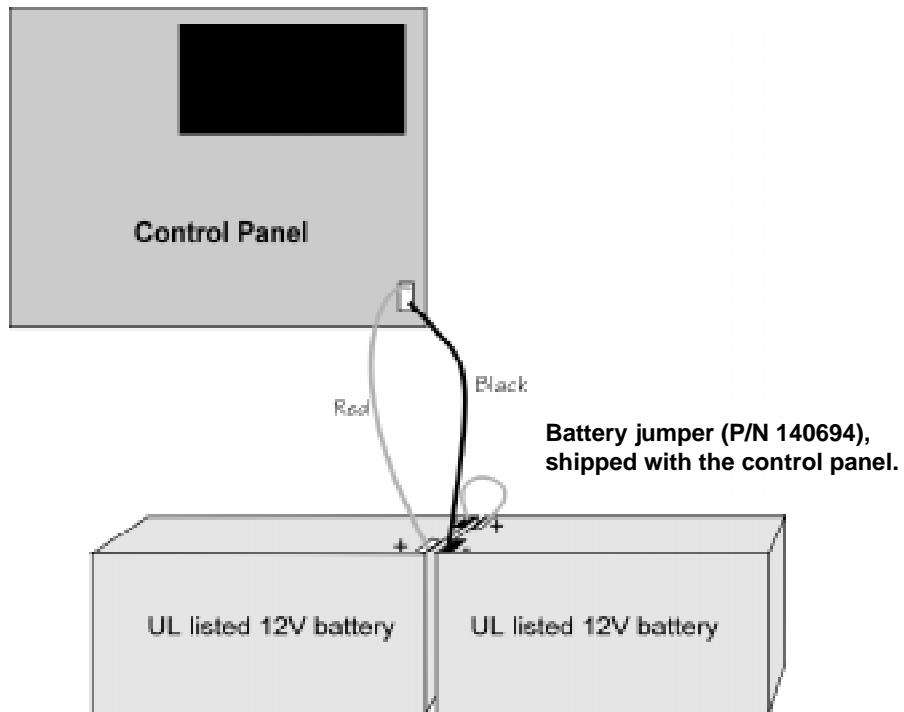

Figure 4-2 Battery Connection

4.3 Initiation Circuit Installation

4.3.1 Contact Wiring

Wire normally open contacts as shown in Figure 4-3. This is the type of wiring that would typically be used for water flow switches, heat detectors and other normally open devices.

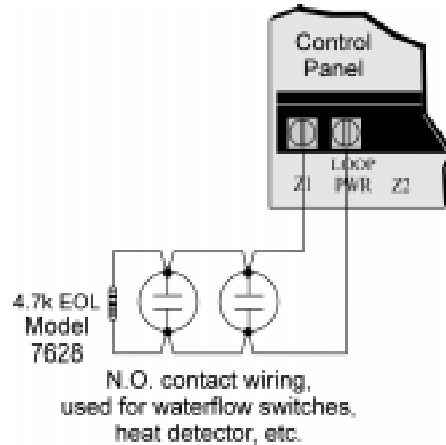

Figure 4-3 N.O. Contact Wiring

4.3.2 Two-Wire Smoke Detector Wiring

Figure 4-4 shows how to connect two-wire smoke detectors to the SK-2224 loops. The figure uses Silent Knight's SLK-24F with HSB-224 base as an example. You can use any detector that has been UL listed for compatibility with the SK-2224. Refer to the Appendix for a list of compatible devices. Refer to Section 5 for configuration options.

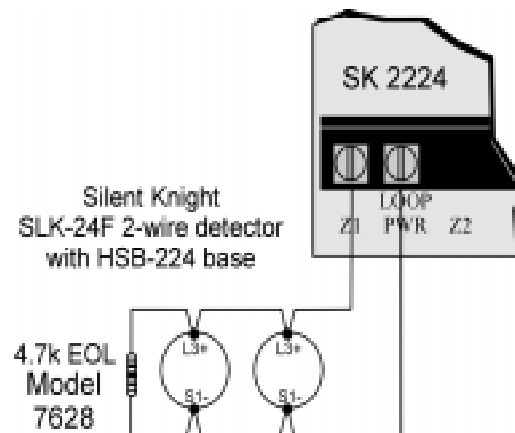

Figure 4-4 Two-Wire Smoke Detector Wiring

4.3.3 Four-Wire Smoke Detector

Figure 4-5 shows how to connect four-wire smoke detectors to the SK-2224 loops. The figure uses Silent Knight's SLK-24F with HSC-4R base as an example. You can use any UL listed device listed in Appendix A. Information on selecting zone configuration options is in Section 5.

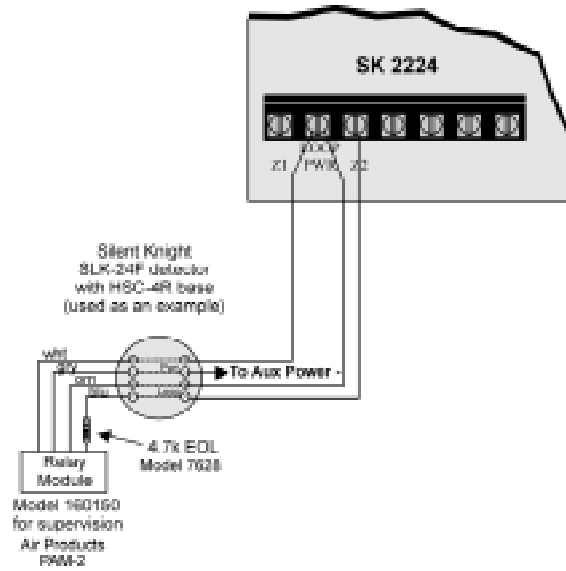

Figure 4-5 Four-Wire Smoke Detector Wiring

4.3.4 Notification Circuit Installation

Notification appliances used with the SK-2224 must be UL listed for compatibility with the SK-2224. Refer to the list in the Appendix at the end of this manual for a list of compatible devices.

For proper operation, you must use polarized notification appliances with a model 7628 4.7k ohm end-of-line (EOL) resistor on each loop. Select ANSI output pattern, if desired. Output is configured as steady (continuous sound) for the factory default. See Section 5 for information on changing the pattern.

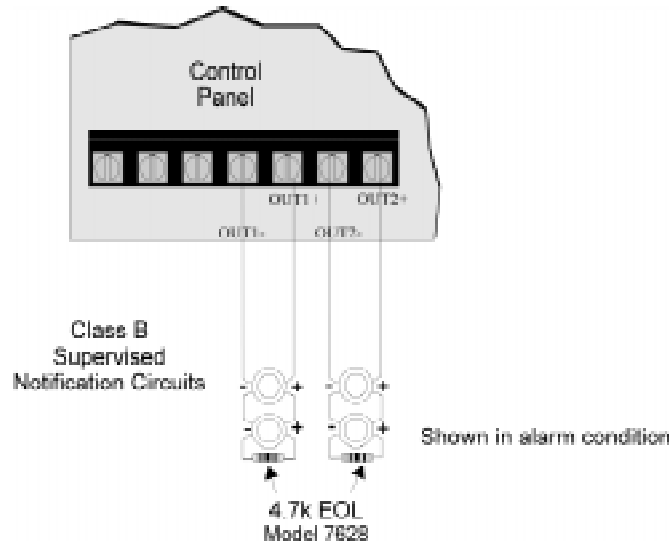

Figure 4-6 Notification Circuit Installation

4.4 Alarm and Trouble Relays

The SK-2224 has built-in relays for alarm and trouble. The alarm relay is energized during any alarm condition. The trouble relay is energized during any trouble or supervisory trouble condition. Each relay has three terminals (N.O., Common, and N.C.). Refer to Figure 3-1 for location of these terminals.

4.5 Auxiliary Power Circuit

The SK-2224 has a power limited auxiliary power circuit which can source up to .5A. The terminal is labeled "AUX PWR". Refer to Figure 3-1 for location of this terminal.

4.6 Door Release Wiring

Figure 4-7 shows how to configure a door release using an ESL DH series door holder.

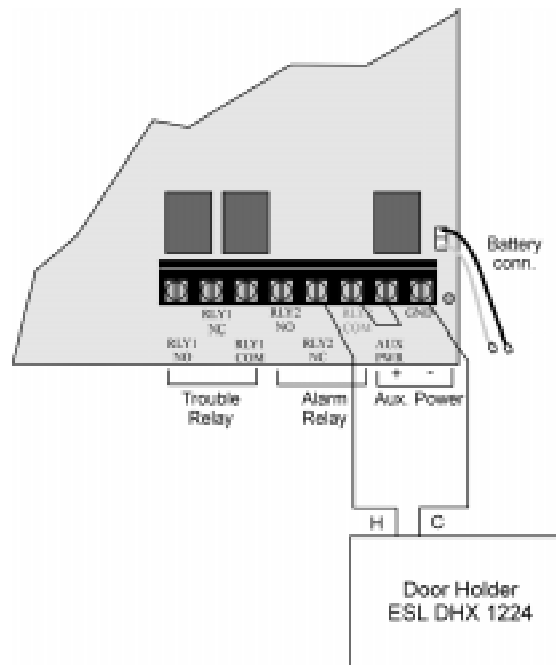

Figure 4-7 Door Release Wiring

4.7 Optional Accessories Installation

This section describes how to install the optional accessories compatible with the SK-2224 control panel.

4.7.1 Installing the Serial Driver Board (Model SK-2884)

The SK-2884 is required if the installation uses any SK-2224 expansion devices such as Model SK2865 (LED Annunciator). The SK-2884 interfaces all the expansion devices to the SK-2224 control panel.

Follow these steps to install the SK-2884 Serial Driver Board:

1. Unplug the AC power connector from the SK-2224 control panel. See Figure 4-1.
2. Unplug the backup battery connector from the SK-2224 control panel. See Figure 4-2.
3. Plug the SK-2884 Serial board on SK-2224 control panel by aligning the 4-pin connector and the stand-offs with their respective receptors. See Figure 4-8.

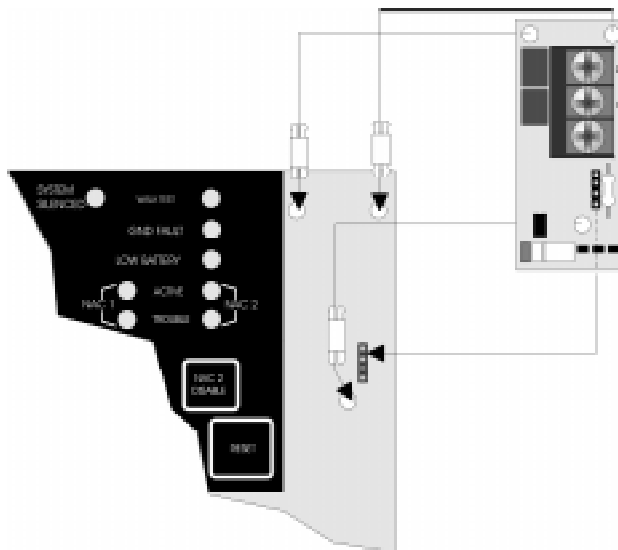

Figure 4-8 SK-2884 Connector and Stand-off alignment

4. Reconnect the AC power connector to the SK-2224 control panel. See Figure 4-1.
5. Reconnect the backup battery connector to the SK-2224 control panel. See Figure 4-2.

Wiring the SK-2884 to an Expansion Device

The SK-2884 uses a three wire connection to all of the SK-2224 compatible expansion devices (see Table 3-2).

Connect all the expansion devices to the SK-2884 as follows:

Table 4-1: SK-2884 Wiring Connections

| SK-2884 Terminals | To SK-2224 Expansion Device Terminal |
|-------------------|--------------------------------------|
| - | - |
| + | + |
| D (Data) | D (Data) |

4.7.2 SK-2865 LED Annunciator Installation

This section describes how to install the SK-2865 LED annunciator. The SK-2865 is a supervised serial device used as a remote LED annunciator unit for the SK-2224.

SK-2865 Electrical Specification

| Circuit | Rating | |
|----------------------|----------|-------|
| Max Loop Resistance: | Data | 50Ω |
| | - | 50Ω |
| | + | 50Ω |
| Max. Current: | Alarm: | 75 mA |
| | Standby: | 35 mA |
| Operating Voltage: | 24 VDC | |

Wiring the SK-2865 to the SK-2884

Follow these steps to properly wire the SK-2865 to the SK-2884:

1. Unplug the AC power connector from the SK-2224 control panel. See Figure 4-1.
2. Unplug the backup battery connector from the SK-2224 control panel. See Figure 4-2.

3. Terminate the wiring as shown in Figure 4-9. See also Table 4-2.

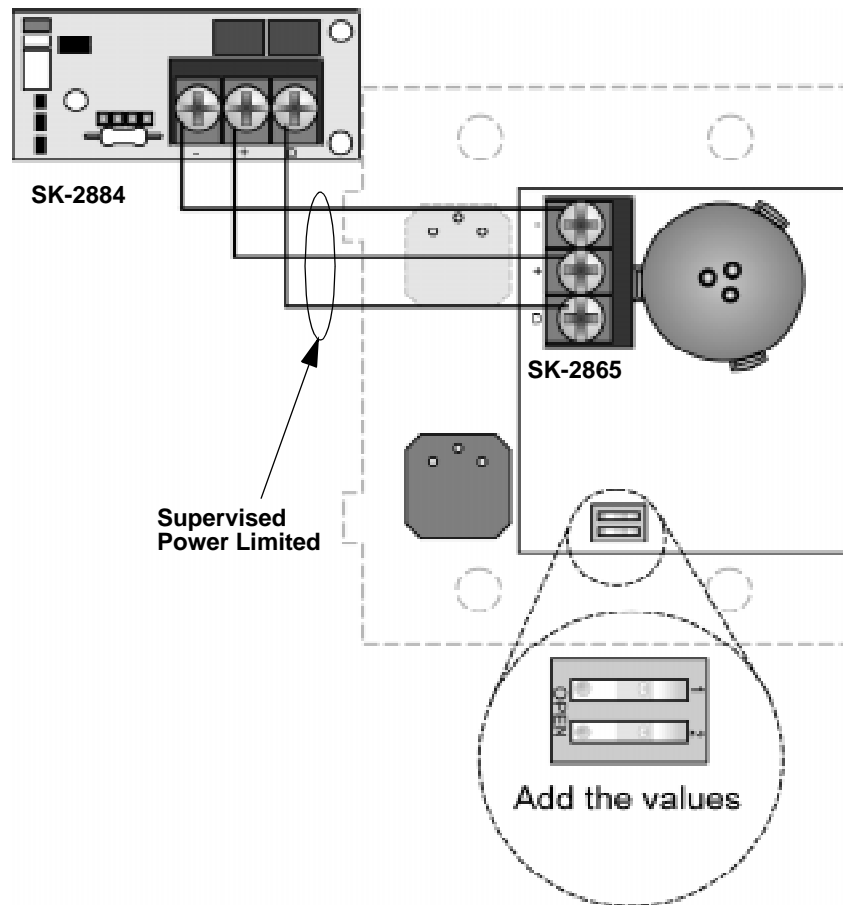

Figure 4-9 SK-2865 Connection to the SK-2884

Table 4-2: SK-2865 Wiring Connections

| SK-2865 Terminals | SK-2884 Terminals |
|-------------------|-------------------|
| D (Data) | D (Data) |
| + | + |
| - | - |

Setting the SK-2865's address

The range of valid addresses is 0-3. Each device requires a unique address. Set the dip switches as shown in Table 4-3. See also Figure 4-9.

Table 4-3: Addresses Per Dip Switch Setting

| Dip Switch | Position | Equivalent Address |
|------------|-------------|--------------------|
| Both | Open (off) | 0 |
| One | Closed (on) | 1 |
| Two | Closed (on) | 2 |
| Both | Closed (on) | 3 |

Mounting the SK-2865

The SK-2865 mounts into a standard 4" square electrical box.

Follow these steps to mount the SK-2865:

1. Make sure that the SK-2865 is properly wired to the control panel. See Figure 4-9.
2. Slide the printed annunciator label into place on the SK-2865. The label fits in between the LEDs and the clear plastic plate.
3. Place the SK-2865 into the 4" square electrical box. See Figure 4-10.

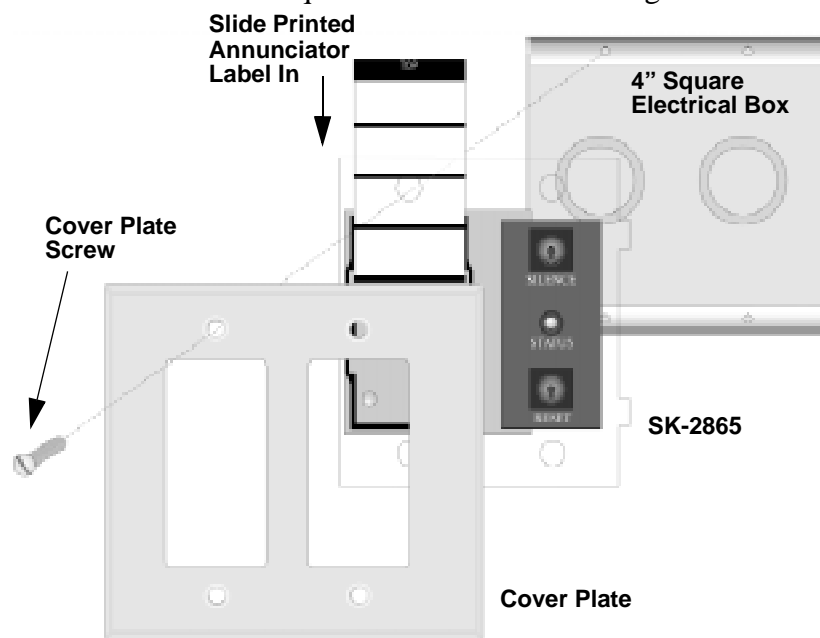

Figure 4-10 Mounting the SK-2865

4. Place the cover plate over the top of the SK-2865 and align the holes. See Figure 4-10.
5. Insert the four cover plate screws into the four screw holes on the 4" square electrical box.
6. Screw the four cover plate screws into the cover plate until the cover plate fits firmly against the SK-2865 and the electrical box. Do not over tighten.

Section 5

System Configuration

To configure the SK-2224 system set the dipswitch that controls the option you want to select. The following chart shows how to program the dipswitches that control system, zone, and notification appliance operation. Refer to Figure 3-1 for location of the dipswitches.

Important!

When you change a dipswitch, be sure to perform a system reset (press [RESET]) or power down the panel. Dipswitch changes will have no effect until after the system has been reset. Some switches are unused and are not referred to in this chart. Leave all unused switches in their factory-programmed OFF position.

Table 5-1: System Configuration

| To Enable | | For Zone 1 (DIP 1) | For Zone 2 (DIP 1) | DIP Position |
|--|-----------------|--------------------|--------------------|---|
| Enhanced mode (dipswitch ON). Use when both pull stations and detectors will be used in the same zone. Normal mode (dipswitch OFF). Use when 4-wire smoke detectors and smoke verification are used in the same zone. | | SW1 | SW6 | ON = Enhanced OFF = Normal |
| Alarm verification Note: Do not use with smoke detectors that have verification built-in. | | SW 2 | SW 7 | ON = Verification zone OFF = No verification |
| Zone Type | Fire alarm | SW 3 | SW8 | OFF |
| | Supervisory | SW 3 | SW8 | ON |
| Alarm delay options Note: Alarm delay options is to be used with water flow devices only. If the device has a built-in delay time the total delay time (device delay + programmed delay) can not exceed 120 seconds. | No delay | SW4 | SW9 | OFF |
| | | SW5 | SW10 | OFF |
| | 30 second delay | SW4 | SW9 | ON |
| | | SW5 | SW10 | OFF |
| 60 second delay | SW4 | SW9 | OFF | |
| | SW5 | SW10 | ON | |
| 90 second delay | SW4 | SW9 | ON | |
| | SW5 | SW10 | ON | |
| To Enable | | For NAC 1 (DIP 2) | For NAC 2 (DIP 2) | DIP Position |
| Silencing | | SW 1 | SW 3 | ON = Can be silenced OFF = No silence |
| ANSI pattern | | SW 2 | SW 4 | ON = ANSI Off = Steady |

Table 5-1: System Configuration

| To Enable | For Entire Panel (DIP 2) | DIP Position |
|--------------------------|--------------------------|--|
| Serial Accessory Devices | SW5 | ON = Serial Annunciator connected to the control panel. OFF = No Serial Annunciator connected to the control panel. |
| | *SW6 | ON = Serial Dialer connected to the control panel OFF = No Serial Dialer connected to the control panel. |
| AC loss report delay | SW7 | ON = 6 hour delay on AC loss report. OFF = No delay on AC (for dialer testing only). Note: If there is not a serial dialer connected to the control panel this should be set to the OFF position. |
| | SW8 | Not Used. |

* *Digital Dialer not available at this time.*

Section 6

System Operation

The annunciator on the SK-2224 board is used for all system operation. It contains the switches for enabling silencing, resetting, and so on. The LEDs that indicate system status are also located on the annunciator.

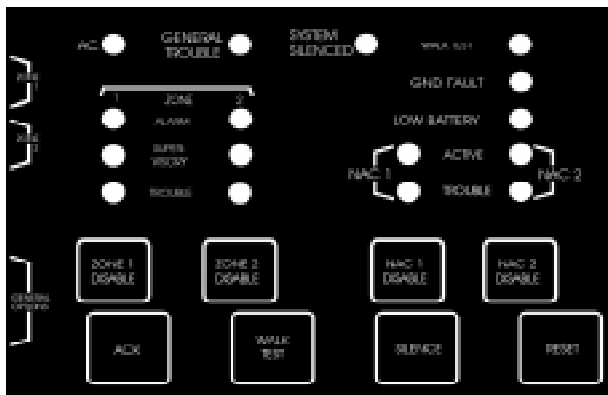

Figure 6-1 On-Board Annunciator

6.1 Meaning of LEDs

The chart below explains the meaning of LEDs on the system board.

Table 6-1: Meaning of LEDs

| LED (Color) | Function | Comments |
|--------------------------|--|--|
| AC (green) | ON = Good AC OFF = Low AC trouble condition and it was acknowledged FLASHING = Unacknowledged AC Low trouble condition | If flashing, press the ACK button to acknowledged the condition. |
| GENERAL TROUBLE (yellow) | ON = System trouble OFF = System OK FLASHING = At least one serial device is in trouble DOUBLE FLASHING = Two types of serial devices are in trouble. | |
| WALK TEST (yellow) | ON = Walk test is in progress OFF = Walk test is off FLASHING = Walk test is on and at least one zone is faulted or not ready | Allow approximately 47 seconds between detector tests. In walk test, when a detector is tripped, it will cause an alarm for two seconds, then the control panel will drop power to the loop for seven seconds to reset the detector. Then an additional 38 seconds is needed to restore the detector. If verification is used, the time between detector test will be about 1 minute and 30 seconds. |

Table 6-1: Meaning of LEDs

| LED (Color) | | Function | Comments |
|--------------------------|----------------------|--|--|
| GND FAULT (yellow) | | ON = Ground fault condition exists and was acknowledged OFF = No fault FLASHING = A ground fault condition detected | If flashing, press the ACK button to acknowledged the condition. |
| LOW BATTERY (yellow) | | ON = Battery low condition that has been acknowledged OFF = Good battery condition FLASHING = Battery low condition | If flashing, press the ACK button to acknowledged the condition. |
| ZONE 1 and ZONE 2 | ALARM (red) | ON = Zone in alarm which has been acknowledged OFF = No Alarm FLASHING = Zone in alarm has not yet been acknowledged. | If flashing, press the ACK button to acknowledged the condition. |
| | SUPERVISORY (yellow) | ON = Zone has a supervisory condition (self-restoring condition) OFF = No supervisory condition exists. FLASHING = supervisory trouble detected on that zone. | If flashing, press the ACK button to acknowledged the condition. |
| | TROUBLE (yellow) | ON = Zone has a trouble condition which has been acknowledged OFF = No zone trouble FLASHING = Zone has a trouble condition DOUBLE FLASHING = Zone was disabled CLEAN ME FLASHING = Indicates that the smoke detector needs cleaning | If flashing, press the ACK button to acknowledged the condition. A “Clean Me Flash” is a flash with a long LED “on” Time and a short LED “off” time indicating that the smoke detector needs cleaning. Applies only to smoke detectors with the CLEAN ME feature. The “Clean Me” flash starts after the trouble condition has been acknowledge. |
| NAC 1 and NAC 2 | ACTIVE (yellow) | ON = NAC is active during an alarm OFF = NAC is not active during alarm | |
| | TROUBLE (yellow) | ON = NAC has a trouble condition and was acknowledged OFF = No trouble condition FLASHING = NAC is in trouble DOUBLE FLASHING = Circuit was disabled | If flashing, press the ACK button to acknowledged the condition. |
| SYSTEM SILENCED (yellow) | | ON = System audio output has been silenced OFF = Nothing silenced FLASHING = Partially silenced | When condition that caused audio activation clears, this condition will clear automatically. Note: Silencing an alarm will cause a general trouble condition. |

6.2 Operation Keys (Switches)

All system operations are performed from the on-board keys (switches) as described in the chart below.

Table 6-2: Operations and Instructions

| Operation | Keystrokes |
|---|---|
| Disable notification appliance circuit. To re-enable the circuit, press [NAC DISABLE] again. | Press the appropriate [NAC DISABLE] key. The NAC circuit will be disabled and the corresponding TROUBLE LED will Double Flash. This function is not available during an alarm condition. |
| Disable a zone To re-enable the circuit, press [ZONE DISABLE] again. | Press the appropriate [ZONE DISABLE] key. The zone will be disabled and the corresponding TROUBLE LED will Double Flash. This function is not available during an alarm or supervisory condition. |
| Begin Walk Test | Press [WALK TEST]. Walk Test LED turns on. Note: Walk test will not activate if the control panel has a trouble, alarm, or supervisory condition. |
| End Walk Test (The test ends automatically after 10 minutes of no system activity.) | Press [WALK TEST]. NOTE: The Walk Test feature is not operational during an alarm, supervisory or any system trouble condition. |
| Acknowledge condition (alarm, supervisory, trouble) | Press [ACK]. The corresponding LED will change from blinking to steady for the duration of the condition. |
| Silence Panel | Press [SILENCE]. This will silence the on-board PZT and all active NAC circuits that have been configured as "silenceable". |
| Perform system reset | Press [RESET]. Resets alarms, supervisories, troubles and all LEDs. |

Appendix A

Compatible Devices

This section of the manual lists devices (smoke detectors and notification appliances) that are compatible with the SK-2224. Contact Silent Knight if you have a question about whether a device not listed here is compatible.

A.1 Smoke Detectors

This section of the manual contains information about smoke detectors that are compatible with the SK-2224.

| | SK-2224 |
|---------------|-----------------|
| Identifier | 24F |
| Voltage Range | 16.2 - 27.3 VDC |

Note: The maximum number of smoke detectors per zone is determined by both the current draw and the impedance of the smoke detector. If too many smoke detectors are used on any zone, false alarms could occur.

Do not mix different models of detectors on any zone; false alarms could occur.

A.1.1 Enhanced Mode

Enhanced mode allows the installer to use pull stations on a loop that has been programmed for Enhanced Alarm Verification. If a single detector goes into alarm it will start the alarm verification cycle. If a pull station is activated any time during the alarm verification cycle and after the control panel re-applies loop power (power will drop for seven seconds to restore detector during verification), the panel will go into immediate alarm and discontinue the verification cycle.

Warning! *Do not mix different models or manufacturers of smoke detectors on the input loops.*

A.1.2 Two-Wire Smoke Detectors

The table below lists two-wire smoke detectors that are compatible with the SK-2224. The table is organized by manufacturer. The columns show the number of detectors per loop that can be used.

Note: The check mark by manufacturers name indicates that this device can be used in enhanced mode.

Table A-1: Compatible Two-Wire Smoke Detectors

| Manufacturer | Enhance Mode Compatible | Model Name or Number (Base model name or number in parentheses.) | Compatibility ID | | # per Loop |
|-------------------|-------------------------|---|------------------|-----------|------------|
| | | | Head | Base | |
| Apollo | | 55000-350 (45681-200) | 55000-350 | 45681-200 | 24 / loop |
| | | 55000-250 (45681-200) | 55000-250 | 45681-200 | 24 / loop |
| Detection Systems | | DS200 (MB200-2W) | A | B | 24 / loop |
| | | DS200HD (MB200-2W) | A | B | 24 / loop |
| | | DS250 (MB2W or MB2WL) | B | A | 18 / loop |
| | | DS250HD (MB2W or MB2WL) | B | A | 18 / loop |
| | | DS250TH (MB2W or MB2WL) | B | A | 18 / loop |
| ESL | | 425 | S10 | N/A | 40 / loop |
| | | 425C | S10 | N/A | 40 / loop |
| | | 425CR | S10 | N/A | 40 / loop |
| | | 425CRT | S10 | N/A | 40 / loop |
| | | 425CT | S10 | N/A | 40 / loop |
| | ✓ | 429C (S10A) | N/A | S10A | 30 / loop |
| | ✓ | 429CRT (S11A) | N/A | S11A | 30 / loop |
| | ✓ | 429CST (S11A) | N/A | S11A | 30 / loop |
| | ✓ | 429CT (S10A) | N/A | S10A | 30 / loop |
| | ✓ | 609U01-11 | S10 | S00 | 40 / loop |
| | ✓ | 609U02-11 | S10 | S00/S03 | 40 / loop |
| | ✓ | 611U (601U or 602U) | S10 | S00/S03 | 40 / loop |
| ✓ | 611UD (601U or 602U) | S10 | S00/S03 | 40 / loop | |
| ESL (Cont.) | ✓ | 611UT (601U or 602U) | S10 | S00/S03 | 40 / loop |
| | ✓ | 612U (601U or 602U) | S10 | S00/S03 | 40 / loop |
| | ✓ | 612UD (601U or 602U) | S10 | S00/S03 | 40 / loop |
| | ✓ | 711U (701E or 701U) | N/A | S10A | 25 / loop |
| | ✓ | 712U (701E or 701U) | N/A | S10A | 25 / loop |
| | ✓ | 713-5U (702E or 701U) | N/A | S10A | 25 / loop |
| | ✓ | 713-6U (702E or 701U) | N/A | S10A | 25 / loop |
| | ✓ | 721-U (S10A) | N/A | S10A | 30 / loop |
| | ✓ | 721-UT (S10A) | N/A | S10A | 30 / loop |

Table A-1: Compatible Two-Wire Smoke Detectors

| Manufacturer | Enhance Mode Compatible | Model Name or Number <i>(Base model name or number in parentheses.)</i> | Compatibility ID | | # per Loop |
|--------------------------|-------------------------|--|------------------|-----------|------------|
| | | | Head | Base | |
| Falcon | ✓ | 525 | FDT1 | N/A | 17 / loop |
| | ✓ | 525T | FDT1 | N/A | 17 / loop |
| Hochiki | ✓ | SIH-24F (HS-224D or HSB-224) | HD-3 | HB-5 | 25 / loop |
| | ✓ | SLK-24F (HS-224D) | HD-3 | HB-5 | 25 / loop |
| | ✓ | SLK-24FH (HS-224D) | HD-3 | HB-5 | 25 / loop |
| System Sensor | ✓ | 1100 | A | N/A | 20 / loop |
| | ✓ | 1100T | A | N/A | 20 / loop |
| | ✓ | 1100TB | A | N/A | 20 / loop |
| | | 1151 (110LP) | A | A | 20 / loop |
| | | 1400 | A | N/A | 20 / loop |
| | ✓ | 1451 (B401B) | A | A | 20 / loop |
| | | 1800 | A | N/A | 20 / loop |
| | | 1851B (B101B) | A | N/A | 20 / loop |
| | | 1851DH (DH1851DC) | A | N/A | 20 / loop |
| | ✓ | 2100 | A | N/A | 20 / loop |
| | ✓ | 2100T | A | N/A | 20 / loop |
| | ✓ | 2100TB | A | N/A | 20 / loop |
| | | 2151 (B110LP or B110LRP) | A | A | 20 / loop |
| | ✓ | 2300T | A | N/A | 20 / loop |
| | ✓ | 2300 | A | N/A | 20 / loop |
| | ✓ | 2300TB | A | N/A | 20 / loop |
| | ✓ | 2400 | A | N/A | 20 / loop |
| | ✓ | 2400 (DH400) | A | N/A | 20 / loop |
| | ✓ | 2400AIT | A | N/A | 20 / loop |
| | ✓ | 2400AT | A | N/A | 20 / loop |
| ✓ | 2400TH | A | N/A | 20 / loop | |
| ✓ | 2451 (B401B) | A | N/A | 20 / loop | |
| System Sensor (Cont.) | ✓ | 2451DH (DH 400) | A | N/A | 20 / loop |
| | ✓ | 2451TH (B401B) | A | N/A | 20 / loop |
| | | 2800 | A | N/A | 20 / loop |
| | | 2800TH | A | N/A | 20 / loop |
| | | 2851B (B101B) | A | A | 20 / loop |
| | | 2851BTH (B101B) | A | A | 20 / loop |
| | | 2851DH | A | A | 20 / loop |
| | 2851TH (B101B) | A | A | 20 / loop | |

A.1.3 Four-Wire Smoke Detectors

Table A-2: Compatible Four-Wire Smoke Detectors

| Manufacturer | Model |
|-------------------|--|
| Silent Knight | SD-P24F with SD-B4@ base |
| Detection Systems | DS200/DS200HD MB200 |
| ESL | 445 Series 449 Series |
| Gentex | 624 824 2040-24 Power Supervision Unit |
| System Sensor | 1851B 2851/2851BTH DH200ADCD |

A.2 Notification Appliances

The chart below lists notification appliances compatible with the SK-2224.

Table A-3: Compatible Notification Devices

| Manufacturer | Model | Type |
|--------------|----------------------|-----------------------------------|
| Amseco | K-MB-6P | 6" Bell |
| Amseco | K-MB-8P | 8" Bell |
| Amseco | K-MB-10P | 10" Bell |
| Faraday | 446X 12/24VDC | Vibrating Bell |
| Faraday | 476X 12/24VDC | Vibrating Bell |
| Faraday | 477X 12/24VDC | Single Stroke Bell |
| Faraday | 5303B-0-14-()-DC | Chime (flush) |
| Faraday | 5304B-0-14-()-DC | Chime (surface) |
| Faraday | 5305B-0-4-()-DC | Chime (ceiling) |
| Faraday | 5306B-0-14-()-24-DC | Chime/Strobe (flush) |
| Faraday | 5307B-0-14-()-24-DC | Chime/Strobe (surface) |
| Faraday | 5308B-0-4-()-24-DC | Chime/Strobe (ceiling) |
| Faraday | 5333B-0-14-24-DC | Multi-Tone Horn (flush) |
| Faraday | 5334B-0-14-24-DC | Multi-Tone Horn (surface) |
| Faraday | 5336B-()-14-24-DC | Multi-Tone Horn/Strobe (flush) |
| Faraday | 5337B-()-14-24-DC | Multi-Tone Horn/Strobe (surface) |
| Faraday | 5338B-()-4-24-DC | Multi-Tone Horn/Strobe (ceiling) |
| Faraday | 5343B-0-14-24-DC | Single Tone Horn/Strobe (flush) |
| Faraday | 5344B-0-14-24-DC | Single Tone Horn/Strobe (surface) |
| Faraday | 5345B-0-4-24-DC | Single Tone Horn/Strobe (ceiling) |
| Faraday | 5348B-()-4-24-DC | Single Tone Horn/Strobe (ceiling) |
| Faraday | 5373B-0-14-24-DC | 8-Tone Horn/Strobe (flush) |
| Faraday | 5374B-0-14-24-DC | 8-Tone Horn/Strobe (surface) |
| Faraday | 5375B-0-4-24-DC | 8-Tone Horn/Strobe (ceiling) |
| Faraday | 5376B-0-14-24-DC | 8-Tone Horn/Strobe (flush) |
| Faraday | 5377B-0-14-24-DC | 8-Tone Horn/Strobe (surface) |
| Faraday | 5378B-0-4-24-DC | 8-Tone Horn/Strobe (ceiling) |
| Faraday | 5405B-0-14-24-DC | Sync Control Unit |

Table A-3: Compatible Notification Devices

| Manufacturer | Model | Type |
|---------------------|--------------------|---|
| Faraday | 5508B-()-14-24-DC | Single Gang Sync Strobe (flush) |
| Faraday | 5521B-()-14-24-DC | 4" Square Sync Strobe (surface) |
| Faraday | 5522B-()-14-24-DC | 4" Square Sync Strobe (flush) |
| Faraday | 6126B-U-14-24 VDC | Horn/Strobe |
| Faraday | 6223B-0-14-24-DC | Horn (flush) |
| Faraday | 6224B-0-14-24-DC | Horn (surface) |
| Faraday | 6225B-0-4-24-DC | Horn (ceiling) |
| Faraday | 6226B-()-14-24-DC | Horn/Strobe (flush) |
| Faraday | 6227B-()-14-24-DC | Horn/Strobe (surface) |
| Faraday | 6228B-()-4-24-DC | Horn/Strobe (ceiling) |
| Faraday | 6243B-0-14-24-DC | Electron-Mechanical Horn (flush) |
| Faraday | 6244B-0-14-24-DC | Electron-Mechanical Horn (surface) |
| Faraday | 6245B-0-4-24-DC | Electron-Mechanical Horn (ceiling) |
| Faraday | 6246B-()-14-24-DC | Electron-Mechanical Horn/Strobe (flush) |
| Faraday | 6247B-()-14-24-DC | Electron-Mechanical Horn/Strobe (surface) |
| Faraday | 6248B-()-4-24-DC | Electron-Mechanical Horn/Strobe (ceiling) |
| Faraday | 6300B-0-14-24-DC | Mini-Horn (flush) |
| Faraday | 6301B-0-14-24-DC | Mini-Horn (surface) |
| Faraday | 6302B-()-4-24-DC | Mini-Horn (ceiling) |
| Faraday | 6310B-0-14-24-DC | Mini-Horn/Strobe/Strobe (flush) |
| Faraday | 6311B-0-14-24-DC | Mini-Horn/Strobe/Strobe (surface) |
| Faraday | 6312B-()-14-24-DC | Mini-Horn/Strobe/Strobe (ceiling) |
| Faraday | 6320B-0-14-24-DC | Sync Mini Horn/Strobe (1 gang) |
| Faraday | 6321B-0-14-24-DC | Sync Mini Horn/Strobe (1,2 gang) |
| Faraday | 6322B-()-14-24-DC | Mini Horn/Sync Strobe (1,2 gang, 4SQ) |
| Federal Signal | 450 | Horn |
| Federal Signal | VALS | Horn/Strobe |
| Gentex | GX90-4 | Horn |
| Gentex | GXS-4-15-1 | Strobe |
| Gentex | GXS-4-1575 | Strobe |
| Gentex | GX90S-4-15 | Horn |
| Gentex | GX90S-4-1575 | Horn |

Table A-3: Compatible Notification Devices

| Manufacturer | Model | Type |
|---------------------|-----------------------|------------------|
| Gentex | HG124 | Horn |
| Gentex | SHG24-1575 | Horn/Strobe |
| Gentex | SHG24-15 | Horn/Strobe |
| Gentex | GMH-24-X | Horn |
| Gentex | GMS-24-X | Horn/Strobe |
| Gentex | GMS-24-X | Horn/Strobe |
| Gentex | G0T24 | Horn |
| Gentex | G0S24-X | Horn |
| Gentex | WGMS-24-X | Horn/Strobe |
| System Sensor | MASS241 | Horn/Strobe |
| System Sensor | MASS24110ADA | Horn/Strobe |
| System Sensor | MASS2415ADA | Horn/Strobe |
| System Sensor | MASS2475ADA | Horn/Strobe |
| System Sensor | SS4110ADA | Strobe |
| System Sensor | SS2415ADA | Strobe |
| System Sensor | SS2475ADA | Strobe |
| System Sensor | PS2415ADA | Mini-Horn/Strobe |
| System Sensor | PS241575ADA | Mini-Horn/Strobe |
| System Sensor | PS24110ADA | Mini-Horn/Strobe |
| System Sensor | PS2475ADA | Mini-Horn/Strobe |
| Wheelock | 46T-G4-24-R | Bell |
| Wheelock | 46T-G6-24-R | Bell |
| Wheelock | 46T-G10-24-R | Bell |
| Wheelock | 46T-G6-24-WS-24-HF-R | Strobe/Bell |
| Wheelock | 46T-G10-24-WS-24-HF-R | Strobe/Bell |
| Wheelock | 46T-G6-24-WH-24-HF-R | Strobe/Bell |
| Wheelock | 46T-G10-24-WH-24-HF-R | Strobe/Bell |
| Wheelock | 700IT-12\24-W-FR | Strobe Horn |
| Wheelock | 7002T-12\24-W-FR | Strobe Horn |
| Wheelock | AES-DL1-R | Multitone Horn |
| Wheelock | AES-EL1-R | Multitone Horn |
| Wheelock | AES-DL1-WS-24-VF-R | Multitone Horn |

Table A-3: Compatible Notification Devices

| Manufacturer | Model | Type |
|---------------------|--------------------|------------------------|
| Wheelock | AES-EL1-WS-24-VF-R | Multitone Horn |
| Wheelock | AES-DL1-WH-24-VF-R | Multitone Horn |
| Wheelock | AES-EL1-WH-24-VF-R | Multitone Horn |
| Wheelock | AES-DL1-WM-24-VF-R | Multitone Horn |
| Wheelock | AES-EL1-WM-24-VF-R | Multitone Horn |
| Wheelock | AH-24-R | Horn |
| Wheelock | AH-24WP-R | Horn |
| Wheelock | AMT-12\24-R | Strobe Horn |
| Wheelock | AMT-24-LS-VFR | Strobe Horn |
| Wheelock | AMT-24-LSM-VFR | Strobe Horn |
| Wheelock | AMT-24-IS-VFR | Strobe Horn |
| Wheelock | AS2415W-FR | Audible Strobe |
| Wheelock | AS241575W-FR | Audible Strobe |
| Wheelock | AS2430W-FR | Audible Strobe |
| Wheelock | AS2475W-FR | Audible Strobe |
| Wheelock | AS24110W-FR | Audible Strobe |
| Wheelock | AS2415C-FW | Audible Strobe |
| Wheelock | AS2430C-FW | Audible Strobe |
| Wheelock | AS2475C-FW | Audible Strobe |
| Wheelock | AS24100C-FW | Audible Strobe |
| Wheelock | AS-2415-VFR | Strobe Horn |
| Wheelock | AS-241575-VFR | Strobe Horn |
| Wheelock | AS-2430-VFR | Strobe Horn |
| Wheelock | AS-2475-VFR | Strobe Horn |
| Wheelock | AS-24110-HFR | Strobe Horn |
| Wheelock | SM-12/24-R | Strobe Horn Controller |
| Wheelock | DSM-12/24-R | Strobe Horn Controller |
| Wheelock | CF-BF1 | Chime |
| Wheelock | CF-BF1-R | Chime |
| Wheelock | CH70-24-R | Chime |
| Wheelock | CH90-24-W | Chime |
| Wheelock | CH70-2415W-FR | Chime Strobe |

Table A-3: Compatible Notification Devices

| Manufacturer | Model | Type |
|---------------------|--------------------------|----------------------------|
| Wheelock | CH70-241575W-FR | Chime Strobe |
| Wheelock | CH70-2430W-FR | Chime Strobe |
| Wheelock | CH70-2475W-FR | Chime Strobe |
| Wheelock | CH70-24110W-FR | Chime Strobe |
| Wheelock | CH-CF1 | Chime |
| Wheelock | CH-CF1-R | Chime |
| Wheelock | CH-CF1-W | Chime |
| Wheelock | CH-DF1 | Chime |
| Wheelock | CH-DF1-R | Chime |
| Wheelock | CH-BF1-WS-24-HF-R | Strobe Chime |
| Wheelock | CH-CF1-LS-24 | Strobe Chime |
| Wheelock | CH-CF1-MS-24 | Strobe Chime |
| Wheelock | CH-CF1-IS-24 | Strobe Chime |
| Wheelock | CH-CF1-LS-24-CFW | Strobe Chime |
| Wheelock | CH-CF1-MS-24-CFW | Strobe Chime |
| Wheelock | CH-CF1-IS-24-CFW | Strobe Chime |
| Wheelock | CH-CF1-WS-24-CF-W | Strobe Chime |
| Wheelock | CH-DF1-LS-24 | Strobe Chime |
| Wheelock | CH-DF1-MS-24 | Strobe Chime |
| Wheelock | CH-DF1-IS-24 | Strobe Chime |
| Wheelock | CH-DF1-LS-24-VFR | Strobe Chime |
| Wheelock | CH-DF1-LSM-24-VFR | Strobe Chime |
| Wheelock | CH-DF1-MS-24-VFR | Strobe Chime |
| Wheelock | CH-DF1-IS-24-VFR | Strobe Chime |
| Wheelock | CH-DF1-WM-24-VFR | Strobe Chime |
| Wheelock | CH-DF1-WS-24-VF-R | Strobe Chime |
| Wheelock | DSM-12/24 | Sync Module |
| Wheelock | EH-DL1-R | Electronic Horn |
| Wheelock | EH-EL1-R Electronic Horn | Electronic Horn |
| Wheelock | EHS-DL1-W-VF-R | Strobe Horn (single input) |
| Wheelock | EHS-EL1-W-VF-R | Strobe Horn (single input) |
| Wheelock | EH-DL1-WS-24-VF-R | Strobe Horn (dual input) |

Table A-3: Compatible Notification Devices

| Manufacturer | Model | Type |
|---------------------|-------------------|--------------------------|
| Wheelock | EH-EL1-WS-24-VF-R | Strobe Horn (dual input) |
| Wheelock | EH-DL1-WH-24-VF-R | Strobe Horn (dual input) |
| Wheelock | EH-EL1-WH-24-VF-R | Strobe Horn (dual input) |
| Wheelock | EH-DL1-WM-24-VF-R | Strobe Horn (dual input) |
| Wheelock | EH-EL1-WM-24-VF-R | Strobe Horn (dual input) |
| Wheelock | HSW-24-HFR | Remote Strobe |
| Wheelock | HS2W-24-HFR | Remote Strobe |
| Wheelock | HSPW-24-HFR | Remote Strobe |
| Wheelock | IS-24-VFR | Remote Strobe |
| Wheelock | IS1-24-VFR | Remote Strobe |
| Wheelock | IS3-24-VFR | Remote Strobe |
| Wheelock | ISP-24-HFR | Remote Strobe |
| Wheelock | LS-24-VFR | Remote Strobe |
| Wheelock | LS1-24-VFR | Remote Strobe |
| Wheelock | LS3-24-VFR | Remote Strobe |
| Wheelock | LSP-24-HFR | Remote Strobe |
| Wheelock | LSM-24-VFR | Remote Strobe |
| Wheelock | LS1M-24-VFR | Remote Strobe |
| Wheelock | LS3M-24-VFR | Remote Strobe |
| Wheelock | LSPM-24-VFR | Remote Strobe |
| Wheelock | MS-24-VFR | Remote Strobe |
| Wheelock | MS1-24-VFR | Remote Strobe |
| Wheelock | MS3-24-VFR | Remote Strobe |
| Wheelock | MSP-24-HFR | Remote Strobe |
| Wheelock | MB-G6-24-R | Motor Bell |
| Wheelock | MB-G10-24-R | Motor Bell |
| Wheelock | MBS-G6-24-W-HF-R | Motor Bell with Strobe |
| Wheelock | MBS-G10-24-W-HF-R | Motor Bell with Strobe |
| Wheelock | MIZ-24-R | Mini-Horn |
| Wheelock | MIZ-24-W | Mini-Horn |
| Wheelock | MIZ-24-LS-VFR | Mini-Horn/Strobe |
| Wheelock | MIZ-24-LSM-VFR | Mini-Horn/Strobe |

Table A-3: Compatible Notification Devices

| Manufacturer | Model | Type |
|---------------------|----------------|-------------------------|
| Wheelock | MIZ-24-MS-VFR | Mini-Horn/Strobe |
| Wheelock | MIZ-24-HSW-HFR | Mini-Horn/Strobe |
| Wheelock | MIZ-24-IS-VFR | Mini-Horn/Strobe |
| Wheelock | MIZ-24-WS-VF-R | Mini-Horn/Strobe |
| Wheelock | MIZ-24-WS-VF-W | Mini-Horn/Strobe |
| Wheelock | MIZ-24-WH-VF-W | Mini-Horn/Strobe |
| Wheelock | MIZ-24-WM-VF-W | Mini-Horn/Strobe |
| Wheelock | MT-12/24-R | Strobe Horn |
| Wheelock | MT4-12/24-R | Multitone Appliance |
| Wheelock | MT4-115-R | Multitone Appliance |
| Wheelock | MT-24-LS-VFR | Strobe Horn |
| Wheelock | MT-24-LSM-VFR | Strobe Horn |
| Wheelock | MT-24-MS-VFR | Strobe Horn |
| Wheelock | MT-24-IS-VFR | Strobe Horn |
| Wheelock | MT-24-SL-VFR | Strobe Horn |
| Wheelock | MT-24-SLM-VFR | Synch. Multitone Strobe |
| Wheelock | MT-24-WM | Strobe |
| Wheelock | MT-24-WM-VF-R | Horn |
| Wheelock | MT-24-WM-VFR | Strobe Horn |
| Wheelock | NH-12/24-R | Horn |
| Wheelock | NS-2415W-FR | Strobe Horn |
| Wheelock | NS-241575W-FR | Strobe Horn |
| Wheelock | NS-2430W-FR | Strobe Horn |
| Wheelock | NS-2475W-FR | Strobe Horn |
| Wheelock | NS-24110W-FR | Strobe Horn |
| Wheelock | NS4-2415W-FR | Strobe Horn |
| Wheelock | NS4-241575W-FR | Strobe Horn |
| Wheelock | NS4-2430W-FR | Strobe Horn |
| Wheelock | NS4-2475W-FR | Strobe Horn |
| Wheelock | NS4-24110W-FR | Strobe Horn |
| Wheelock | RS-2415W-FR | Strobe |
| Wheelock | RS-2415W-FR | Strobe |

Table A-3: Compatible Notification Devices

| Manufacturer | Model | Type |
|---------------------|----------------|----------------------------|
| Wheelock | RS-241575W-FR | Strobe |
| Wheelock | RS-2415-HFR | Strobe |
| Wheelock | RSP-2415-VFR | Strobe |
| Wheelock | RS-241575-VFR | Strobe |
| Wheelock | RSP-241575-VFR | Strobe |
| Wheelock | RS-2430-VFR | Strobe |
| Wheelock | RS-2430-HFR | Strobe |
| Wheelock | RS-2475-VFR | Strobe |
| Wheelock | RSP-2475-HFR | Strobe |
| Wheelock | RS-24110-HFR | Strobe |
| Wheelock | RSP-24110-HFR | Strobe |
| Wheelock | RSS-2415W-FR | Strobe |
| Wheelock | RSS-241575W-FR | Strobe |
| Wheelock | RSS-2430W-FR | Strobe |
| Wheelock | RSS-2475W-FR | Strobe |
| Wheelock | RSS-24110W-FR | Strobe |
| Wheelock | RSS-2415C-FW | Strobe |
| Wheelock | RSS-2430C-FW | Strobe |
| Wheelock | RSS-2475C-FW | Strobe |
| Wheelock | RSS-24100C-FW | Strobe |
| Wheelock | RSSP-2415W-FR | Strobe |
| Wheelock | RSSP-241575-FR | Strobe |
| Wheelock | RSSP-2430W-FR | Strobe |
| Wheelock | RSSP-2475W-FR | Strobe |
| Wheelock | RSSP-24110W-FR | Strobe |
| Wheelock | SL-24-VFR | Synchronized Remote Strobe |
| Wheelock | SL1-24-VFR | Synchronized Remote Strobe |
| Wheelock | SL3-24-VFR | Synchronized Remote Strobe |
| Wheelock | SLP-24-VFR | Synchronized Remote Strobe |
| Wheelock | SLM-24-VFR | Synchronized Remote Strobe |
| Wheelock | SL1M-24-VFR | Synchronized Remote Strobe |
| Wheelock | SL3M-24-VFR | Synchronized Remote Strobe |

Table A-3: Compatible Notification Devices

| Manufacturer | Model | Type |
|---------------------|-------------------|-------------------------------------|
| Wheelock | SLPM-24-VFR | Synchronized Remote Strobe |
| Wheelock | SHW-24-VFR | Synchronized Remote Strobe |
| Wheelock | SH2W-24-VFR | Synchronized Remote Strobe |
| Wheelock | SHPW-24-VFR | Synchronized Remote Strobe |
| Wheelock | SCM-24-R | Controller for Synchronized Strobes |
| Wheelock | SM-12/24-R | Sync Module |
| Wheelock | SR-2415-VFR | Sync Strobe |
| Wheelock | SRP-2415-HFR | Sync Strobe |
| Wheelock | SR-241575-VFR | Sync Strobe |
| Wheelock | SRP-241575-VFR | Sync Strobe |
| Wheelock | SR-2475-VFR | Sync Strobe |
| Wheelock | SR-2475-HFR | Sync Strobe |
| Wheelock | SR-24110-HFR | Sync Strobe |
| Wheelock | SRP-24110-HFR | Sync Strobe |
| Wheelock | V7001T-12\24-W-FR | Strobe Horn |
| Wheelock | WM3T-24-FR | Remote Strobe |
| Wheelock | WM3T-24-VFR | Remote Strobe |
| Wheelock | WS1T-24-FR | Strobe |
| Wheelock | WS3T-24-FR | Strobe |
| Wheelock | WST-24-FR | Strobe |

Silent Knight Fire Product Warranty and Return Policy

General Terms and Conditions

- All new fire products manufactured by Silent Knight after September 1, 1997 have a limited warranty period of 18 months from the date of manufacture against defects in materials and workmanship. See limited warranty statement for details.
- This limited warranty does not apply to those products that are damaged due to misuse, abuse, negligence, or have been modified in any manner whatsoever.

Repair and RA Procedure

- All products that are returned to Silent Knight for credit or repair require a RA (Return Authorization) number. Call Silent Knight Customer Service at 800-446-6444 or 612-493-6435 between 8:00 A.M. and 5:00 P.M. CST, Monday through Friday to obtain a return authorization number. Silent Knight Technical Support is available at 800-328-0103 between 8:00 A.M. and 7:00 P.M. CST, Monday through Friday.
- RA number must be prominently displayed on the outside of the shipping box. See return address example under Advanced Replacement Policy.
- All products returned to Silent Knight must be sent freight pre-paid. After product is processed, Silent Knight will pay for shipping product back to customer.
- Return the Silent Knight product circuit board only. Products that are returned in cabinets will be charged an additional \$20 to cover the extra shipping and handling costs over board only returns. Do not return batteries. Silent Knight has the authority to determine if a product is repairable. Products that are deemed un-repairable will be returned to the customer.
- Product that is returned that has a board date code more than 18 months from date of manufacture will be repaired and the customer will be assessed the standard Silent Knight repair charge for that model.
- A detailed description of the problem should be included with each return.

Advanced Replacement Policy

- Silent Knight offers an option of advance replacement for fire product printed circuit boards that fail during the 18 month warranty period.
- For advance replacement of a defective board call Silent Knight at 800-446-6444 or 612-493-6435 to obtain a RA (Return Authorization) number and request advanced replacement.
- Customers must use a MasterCard or Visa credit card to get an advance replacement.

- A new or refurbished board will be shipped to the customer. The customer will initially be billed for the replacement board but a credit will be issued after the repairable board is received at Silent Knight.
- The defective board must be returned within 30 days of shipment of replacement board for customer to receive credit. No credit will be issued if the returned board was damaged due to misuse or abuse.
- Repairs and returns should be sent to:

Silent Knight

Attn: Repair Department

7550 Meridian Circle

Maple Grove, MN 55369-4927

RA Number:_____

Limited Warranty

Silent Knight warrants that the products of its manufacture shall be free from defects in materials or workmanship for 18 months from the manufacturing date code on the printed circuit board, if such goods have been properly installed, are subject to normal proper use, and have not been modified in any manner whatsoever. Upon return of the defective product to the nearest Silent Knight, Silent Knight will, at its sole discretion, either repair or replace, at no cost, such goods as may be of defective material or workmanship. Customers outside the United States are to return products to their distributor for repair.

SILENT KNIGHT SHALL NOT UNDER ANY CIRCUMSTANCES BE LIABLE FOR ANY INCIDENTAL OR CONSEQUENTIAL DAMAGES ARISING FROM LOSS OF PROPERTY OR OTHER DAMAGE OR LOSSES OWING TO THE FAILURE OF SILENT KNIGHT SECURITY SYSTEMS PRODUCTS BEYOND THE COST OF REPAIR OR REPLACEMENT OF ANY DEFECTIVE PRODUCTS.

SILENT KNIGHT MAKES NO WARRANTY OF FITNESS OR MERCHANTABILITY AND NO OTHER WARRANTY, ORAL OR WRITTEN, EXPRESS OR IMPLIED, BEYOND THE 18 MONTH WARRANTY EXPRESSLY SPECIFIED HEREIN.

SK-2224 Basic Operating Instructions P/N 151055

These instructions must be framed and displayed next to the SK-2224 panel in accordance with NFPA 72 fire code for Local Fire Alarm System.

| LED (Color) | Function |
|--------------------------|---|
| AC (green) | ON = Good AC OFF = Low AC trouble condition and it was acknowledged FLASHING = Unacknowledged AC Low trouble condition |
| GENERAL TROUBLE (yellow) | ON = System trouble OFF = System OK FLASHING = At least one serial device is in trouble DOUBLE FLASHING = Two types of serial devices are in trouble. |
| WALK TEST (yellow) | ON = Walk test is in progress OFF = Walk test is off. FLASHING = Walk test is on and at least one zone is not ready |
| GND FAULT (yellow) | ON = Ground fault condition exists and was acknowledged OFF = No fault FLASHING = A ground fault condition detected |
| LOW BATTERY (yellow) | ON = Battery low condition that has been acknowledged OFF = Good battery condition FLASHING = Battery low condition |
| ZONE 1 and ZONE 2 | ALARM (red) ON = Zone in alarm which has been acknowledged OFF = No Alarm FLASHING = Zone in alarm has not yet been acknowledged. |
| | SUPERVISORY (yellow) ON = Zone has a supervisory condition (self-restoring condition) OFF = No supervisory condition exists. FLASHING = supervisory trouble detected on that zone. |
| | TROUBLE (yellow) ON = Zone has a trouble condition which has been acknowledged OFF = No zone trouble FLASHING = Zone has a trouble condition DOUBLE FLASHING = Zone was disabled CLEAN ME FLASHING = Indicates that the smoke detector needs cleaning (LED is on long and Off for a short time period) |
| NAC 1 and NAC 2 | ACTIVE (yellow) ON = NAC is active during an alarm OFF = NAC is not active during alarm |
| | TROUBLE (yellow) ON = NAC has a trouble condition and was acknowledged OFF = No trouble condition FLASHING = NAC is in trouble DOUBLE FLASHING = Circuit was disabled |
| SYSTEM SILENCED (yellow) | ON = System audio output has been silenced OFF = Nothing silenced FLASHING = Partially silenced |

Cut Along the Dotted Line

| Operation | Keystrokes |
|---|--|
| Disable notification appliance circuit. To re-enable the circuit, press [NAC DISABLE] again. | Press the appropriate [NAC DISABLE] key. The NAC circuit will be disabled and the corresponding TROUBLE LED will Double Flash. This function is not available during an alarm condition. |
| Disable a zone To re-enable the circuit, press [ZONE DISABLE] again. | Press the appropriate [ZONE DISABLE] key. The zone will be disabled and the corresponding TROUBLE LED will Double Flash. This function is not available during an alarm or supervisory condition. |
| Begin Walk Test | Press [WALK TEST]. Walk Test LED turns on. Note: Walk test will not activate if the control panel has a trouble, alarm, or supervisory condition. |
| End Walk Test | Press [WALK TEST]. NOTE: The Walk Test feature is not operational during an alarm, supervisory or any system trouble condition. The test ends automatically after 10 minutes of no system activity. |
| Acknowledge condition (alarm, supervisory, trouble) | Press [ACK]. The corresponding LED will change from blinking to steady for the duration of the condition. |
| Silence Panel | Press [SILENCE]. This will silence the on-board PZT and all active NAC circuits that have been configured as "silenceable". |
| Perform system reset | Press [RESET]. Resets alarms, supervisories, troubles and all LEDs. |

For Service Contact:

| |
|--|
| |
|--|

